



# Distributed and Mobile Systems

---

Professor Christopher Gill  
Computer Science and Engineering

# Outline: Distributed/Mobile Systems

---

- Overview of distributed and mobile systems
- Security and middleware
- *Application*: Mobile ad hoc computing
  - Open problem: securing mobile ad hoc systems
  - Security features for tuple space middleware
- *Application*: Distributed real-time embedded systems
  - Open problem: security in a real-time setting
  - Real-time properties as vulnerabilities and assets



# What is a Distributed System?

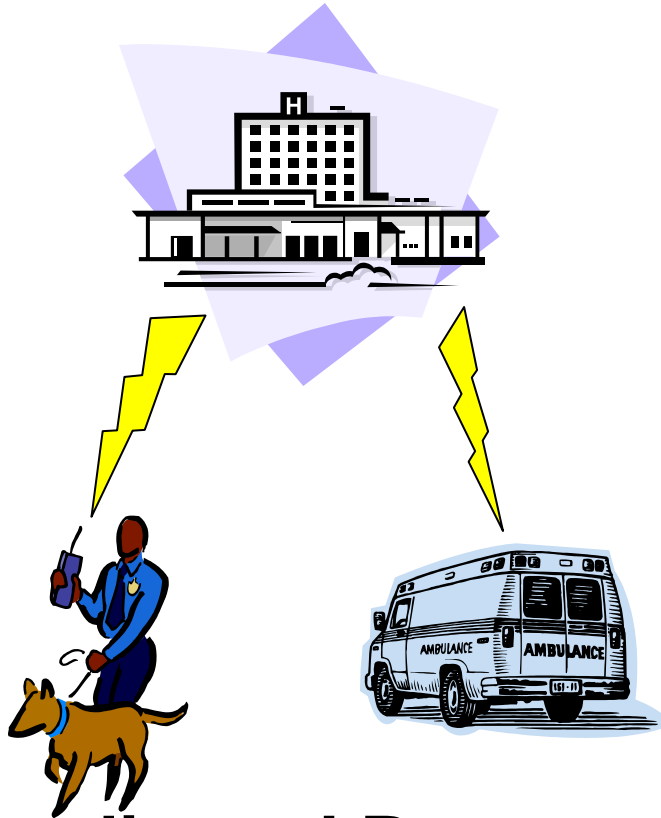

**Coordinated Response**

- Spans multiple computers
  - Sensors to supercomputers
  - On-board to world-wide
- Mixture of infrastructure
  - Wired/fixed ad hoc/mobile
- Key challenges
  - Network connectivity
  - System crashes/faults
  - Resources, quality of service
  - **Security**

# What is a Mobile System?

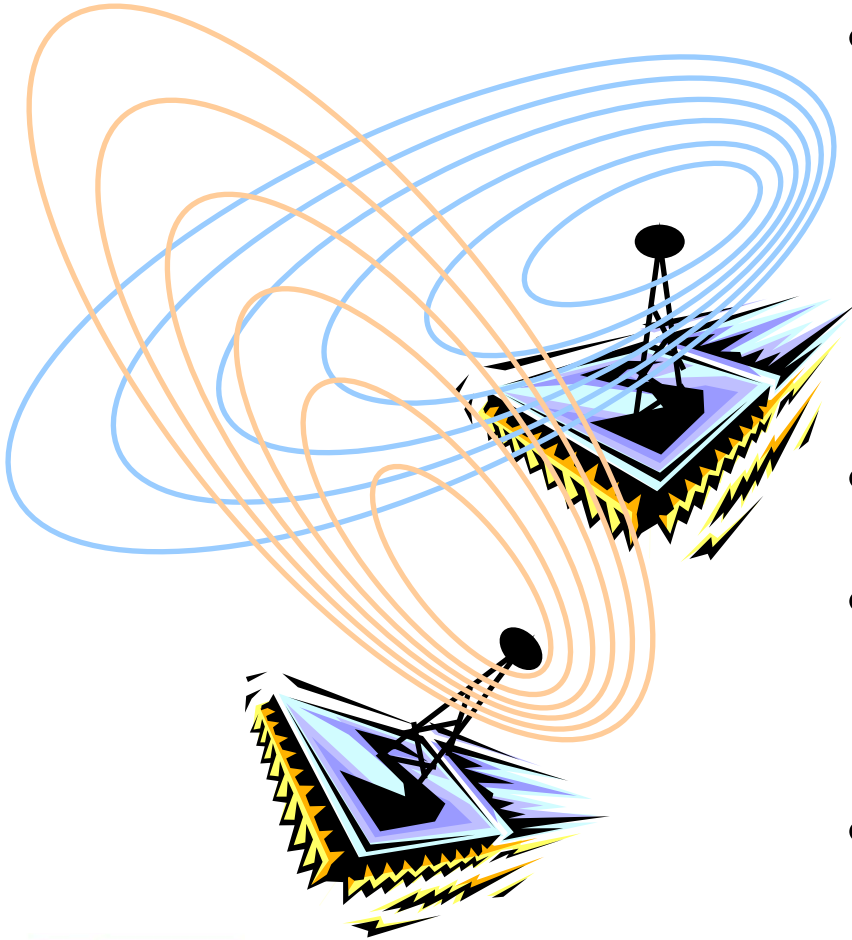

- A particularly challenging kind of distributed system
  - Mobile/motile nodes
  - Sporadic connectivity
- Coordination is crucial
- Physical properties
  - Node distance/velocity
- May exploit fixed infrastructure

# Distributed Systems Challenges

---

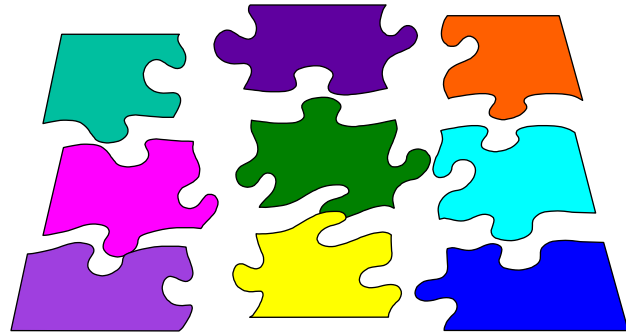

## Distributed Application

- Design Tension
  - Single-system solutions
    - Too expensive to maintain
    - Difficult to evolve
  - Purely off-the-shelf solutions
    - May not meet key needs
    - *E.g.*, Real-time constraints
    - *E.g.*, Security requirements

# Building Distributed Systems

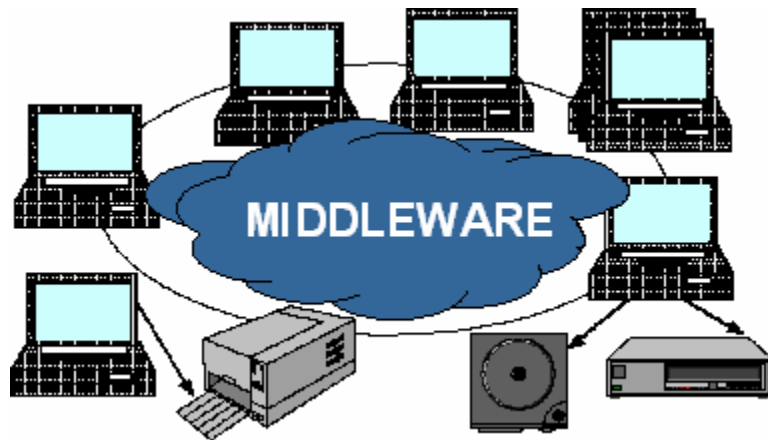

- Solution
  - Customizable Middleware
    - Distinct from distributed operating systems
      - Abstractions closer to application
      - Prevalent in practice
    - Designed for classes of systems
    - Can be tailored to particular application requirements
- Examples from WU research
  - LIME, TAO, nORB

# Security of Middleware

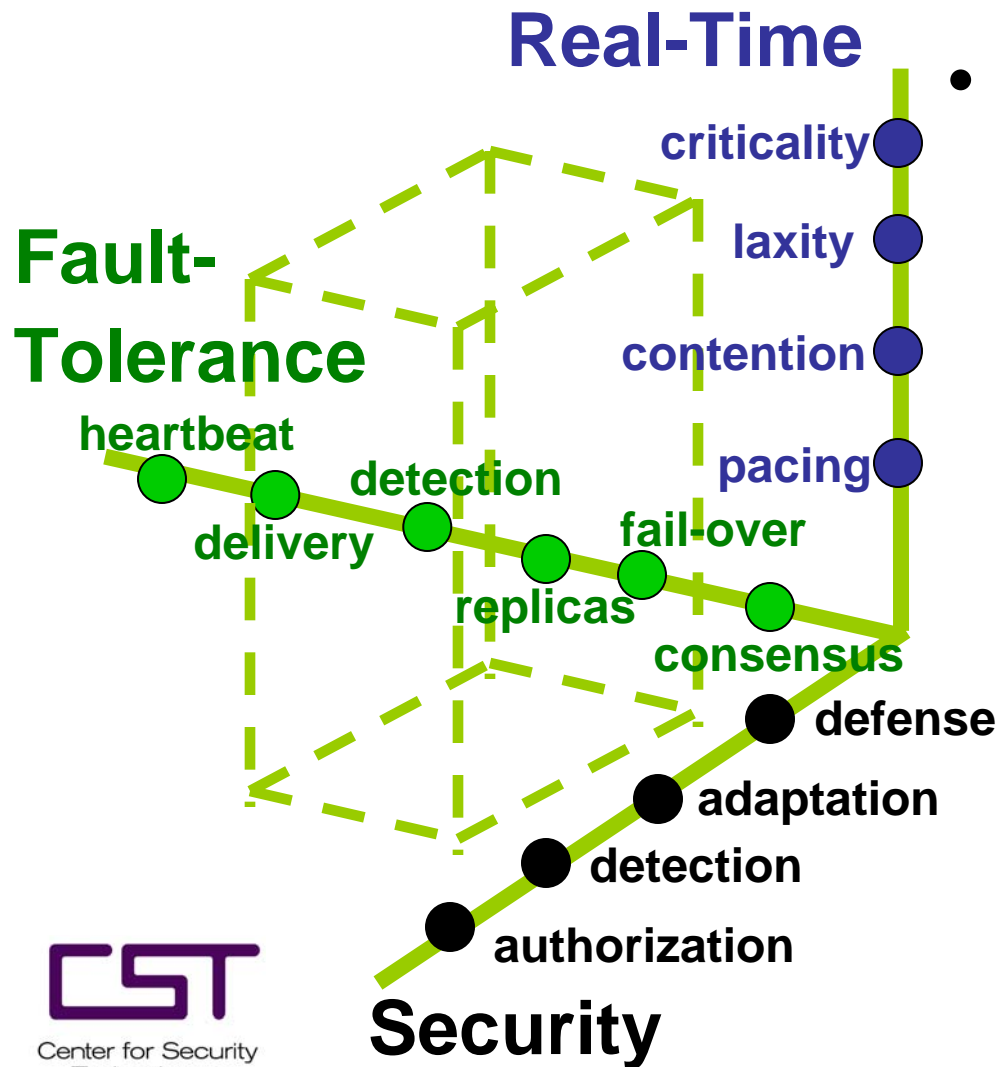

- The security dimension
  - Vulnerability to threats
    - Intrusion, subversion
    - Interference with real-time, fault-tolerance
  - Participation in own defense
    - Protecting middleware
    - Apply lessons from real-time, fault-tolerance

# Middleware for Security Systems

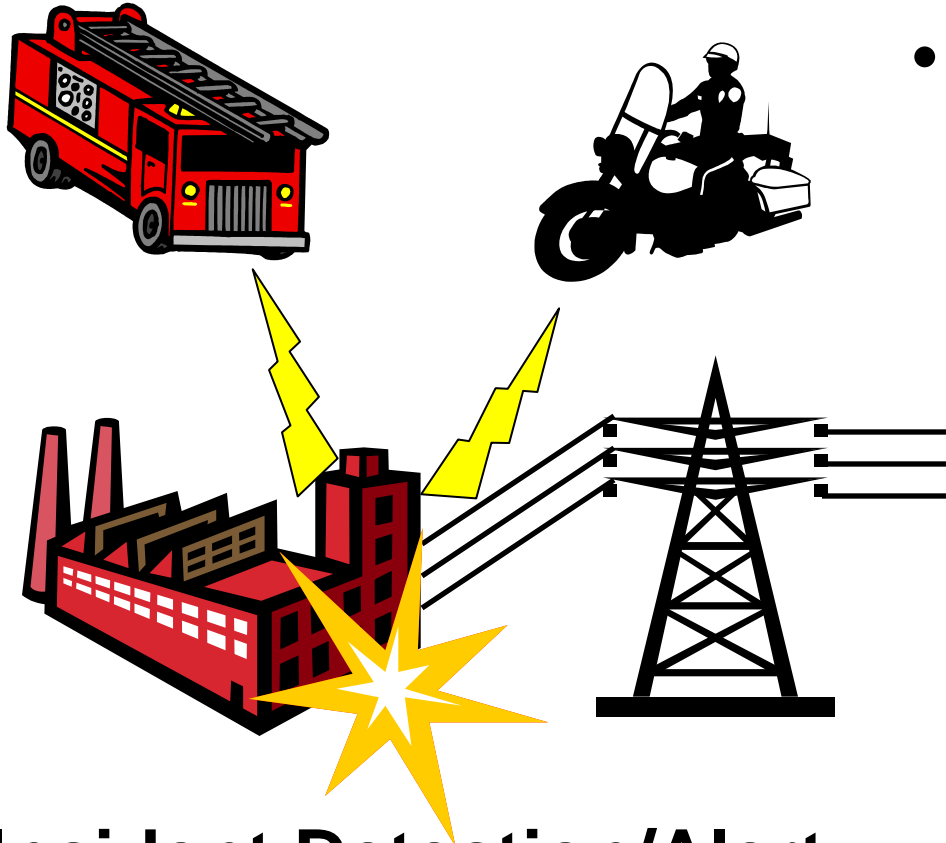

**Incident Detection/Alert**

- Middleware as security systems infrastructure
  - Manages distribution
    - Remote monitoring
    - Data/command routing
  - Supports key system properties
    - Timely event response
    - Reliable alerts

# Mobile Security Challenges

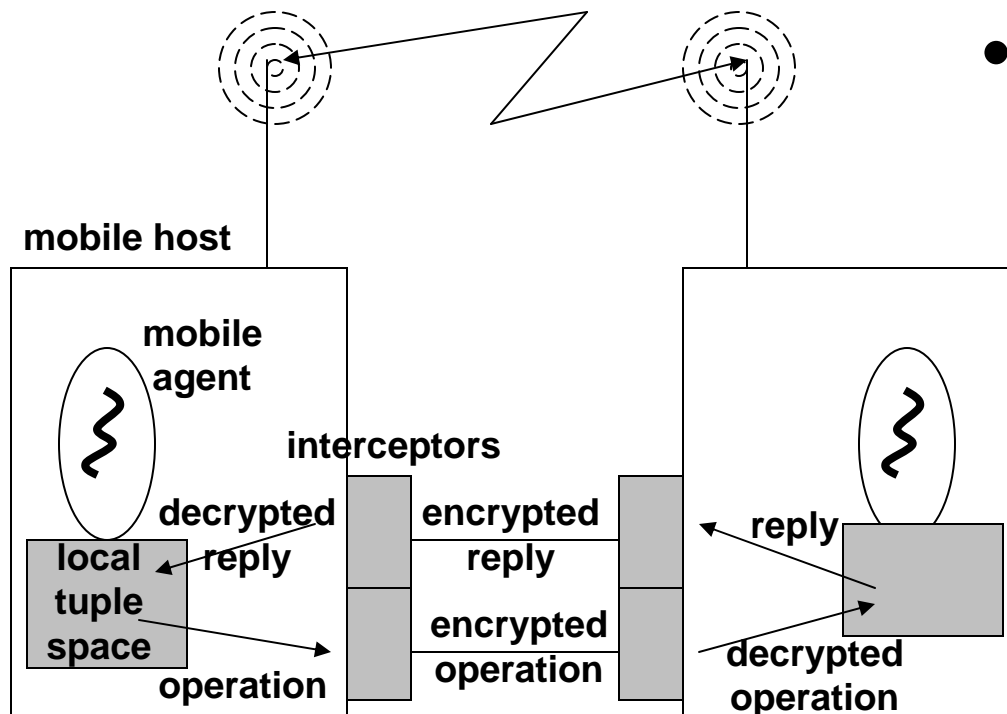

- Classic Security Issues

- But in a mobile ad hoc setting

- Read/write permissions
- Password Protection
- Secure Remote Access

# Security of Mobile Systems

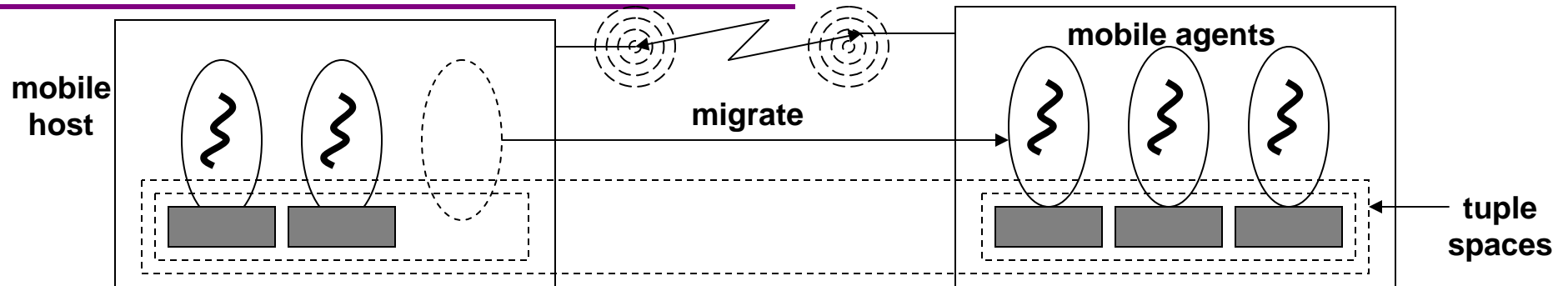

- Shared Tuple Space Model
  - Data “bulletin board” for mobile systems
- Tuple-level access control/authorization
- Password protect tuple space access
- Encrypt tuples sent between agents

# Real-Time Security Challenges

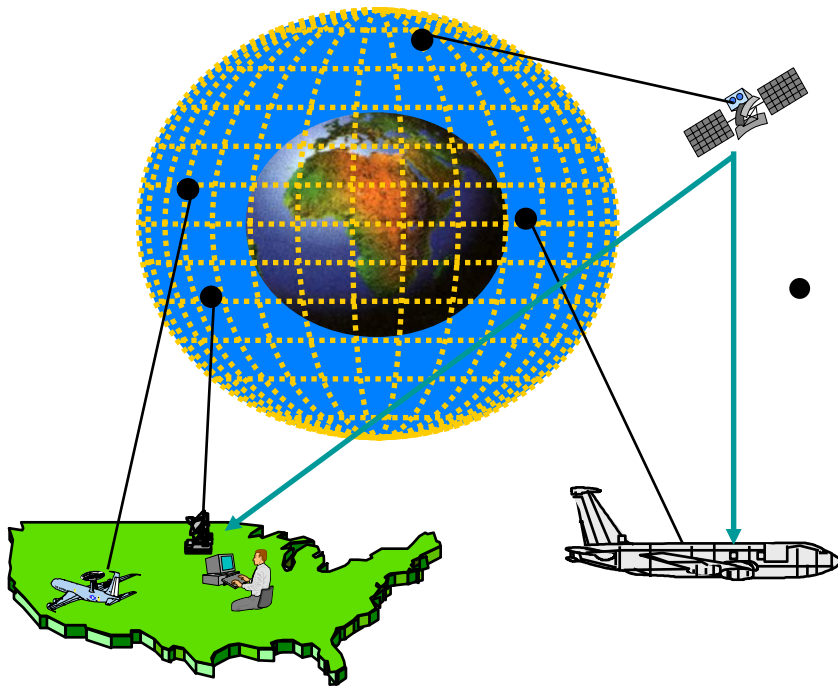

- Stringent assurances
  - *E.g.*, end-to-end timeliness
  - Vulnerable to attack
- Specific focus on quality of service properties
  - Real-time delivery of events
  - Scheduling resources/tasks
  - Data/processing replication
  - Failure detection/handling

# Security of Real-Time Systems

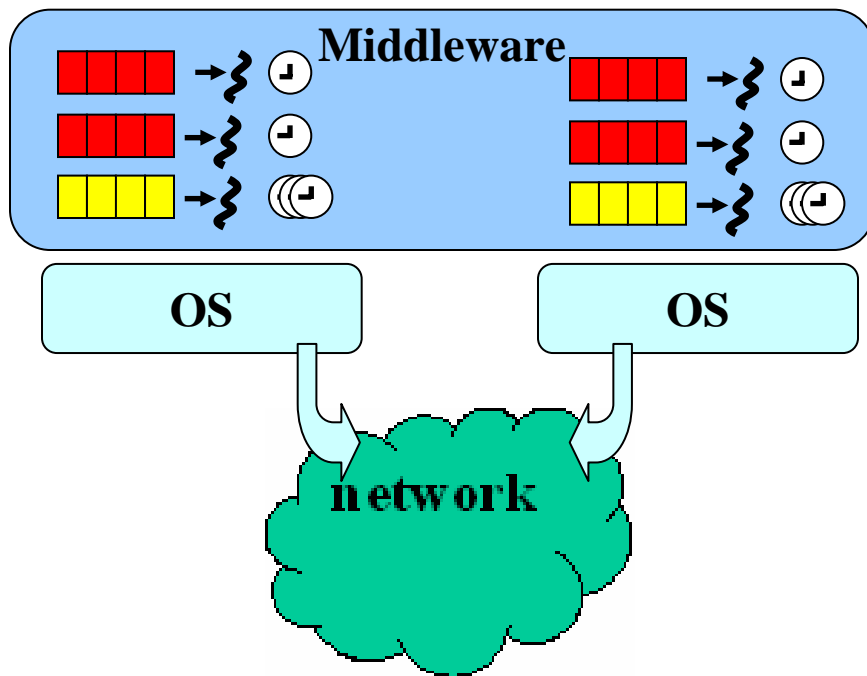

- Approach: expand on productive techniques
  - Study security
    - As a key quality of service dimension
  - System participation in its own defense
  - Co-design
    - Security, real-time, fault-tolerance properties

# Concluding Remarks

---



## Distributed and Mobile Systems

- Middleware and security research converging
  - Mobile and ad hoc computing (ongoing)
  - Distributed real-time embedded systems (new)
- Middleware research
  - Can help in building better security systems
- Security research
  - Can improve resilience of middleware itself